

Part # SC-9600, the original, spring return, **SCHULTZ 3 - WAY DIFFERENTIAL PRESSURE TEST VALVE** is designed to allow a hydraulic test movement of the D/P gauge piston. This is done by venting the lower piston chamber, and allowing the line pressure to drive the piston into its maximum low position. During this test, you observe the piston's movement to insure smooth and continuous operation.

To perform this test, the filter must be flowing fuel through the system. With 3 - way valve clockwise, observe the pistons movement to scale. The valve will automatically return the gauge to its normal operation pressure when the handle is released.

Valve may be mounted on the bottom of the gauge, or remotely installed on panels or walls, using tubing.

FEATURES

- Works with two ranges of D/P Gauges:
 - (1) 0 - 15 psi
 - (2) 0 - 30 psi
- Stainless Steel & Aluminum Alloy
- Seals, Viton & Teflon
- Stainless Steel Ball
- Single hand Test Operation
- Stop Pins to prevent Seal Damage

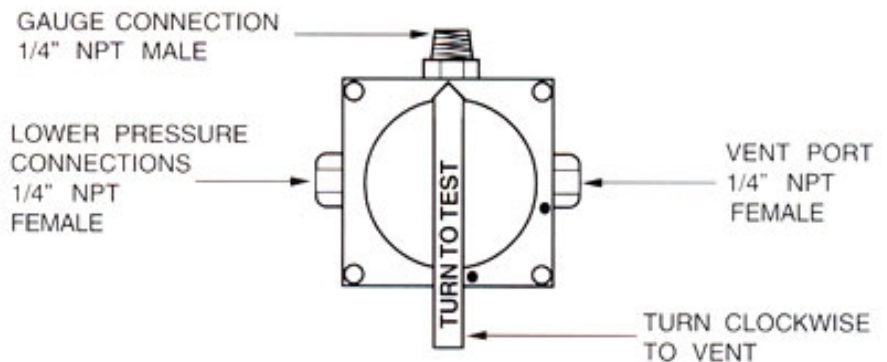
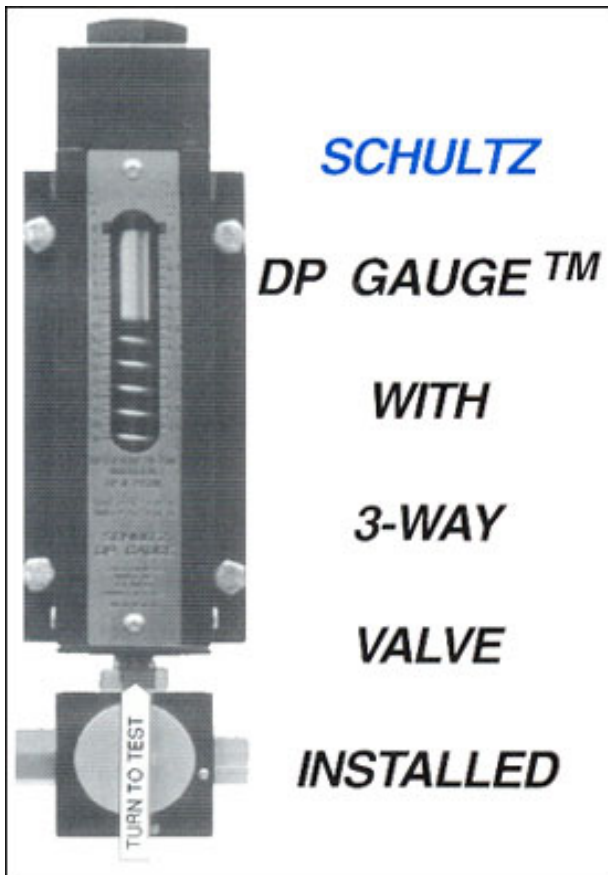

THE ORIGINAL SCHULTZ 3-WAY VALVE

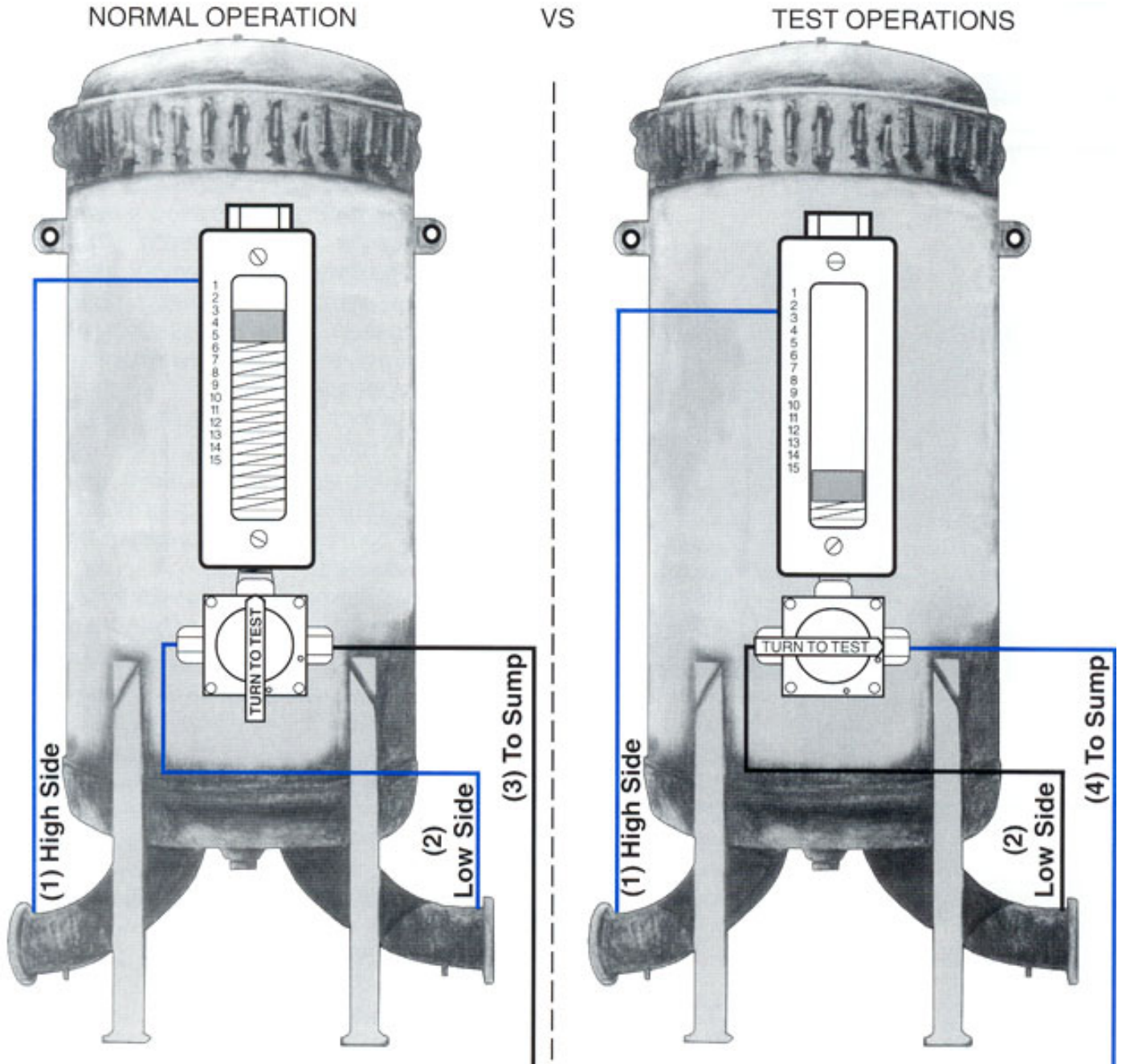

Normal Operations

Test Operations

Normal Operations

- When the 3-way valve is in the normal, spring loaded (closed) position, fuel pressure flows through the high side entrance flange (1), and into the top of the piston maybe noticeable.
- The low side fuel pressure (2) is ported through the bottom of the DP gauge, through the top of the 3-way valve, and into a fitting on the left side to the valve. That fitting is hard piped to the exit for the filter.
- During normal operation, the 3-way valve closes off the vent port to the sump (3). When fuel flows, the gauge works normally, indicating the difference in pressure from the inlet side to the exit side of the equipment.

Test Operations

- During a test, fuel pressure flows to the high side (1) of the differential pressure gauge normally. When the spring loaded handle is turned clockwise, the low side port (2) is blocked by the 3-way valve.
- At the same time, pressure on the bottom of the piston is vented to the sump (4). While this is taking place, you should observe pressure from the top of the piston, moving the piston downward, to the bottom of the differential pressure gauge.
- When the 3-way valve is released, the spring action returns the valve handle to normal operations. The gauge piston should return to the same PSI reading as before the test in one continuous motion.