

Duplex Bag Filters And Basket Strainers

Trouble free, continuous operation

Duplex filters permit continuous operation, reducing overall operating costs. Flow can be switched back and forth between two filter vessels or housings, allowing one side to be serviced while the other is in use.

The Rosedale duplex, using a single multi-ported valve operating system (patent applied for), is a better solution, and offers many benefits:

- Four separate valves are used all operated simultaneously by a single lever.
- Valves use the standard butterfly design, known for their effective seal, low pressure drop, and low cost.
- Any of the valves can be serviced individually, without need to disturb the other valves or piping. Replacements are readily available.
- Valves are soft-seated to provide bubble-tight closure.
- A variety of valve seal materials is available for use with a number of hard-to-handle fluids.
- Pressure drop is minimized because the flow path has the equivalent of only four elbows instead of the usual six.
- Mechanical stops assure that the valves are completely open or closed.
- A single-valve pressure balancing vent system is furnished to ease movement of the lever and to fill the just serviced vessel before use.
- Vents in filter covers and drain ports in filter housing speed evacuation and filling.
- Remotely operated power actuators and automatic power actuation (triggered by pressure differential sensing) are offered. Air or electric actuation is best if such power is available.



Construction Materials

Available in carbon steel, 304 stainless steel, or 316 stainless steel.

Internal valve parts other than seals are 316 stainless steel.

Four different materials can be ordered for all seals involved.

All baskets and mesh linings are made of stainless steel. 304 stainless will be supplied with carbon and 304 housings, 316 stainless with 316 housings.

Choosing a Basket Strainer or Bag Filter

Choose between straining a fluid (removing particles down to 74 micron size) and filtering it (removing particles down to 1 micron).

Pressure Drop Data

Basket strainers and bag filters are usually selected so that the pressure drop does not exceed 2 psi, when they are clean. Higher pressure drops may be tolerated, when contaminant loading is low.

The pressure drop data are accurate for all housings with strainer or filter bag baskets. When filter bags are added, total pressure drop becomes the sum of the pressure drop as determined by the steps below plus the pressure drop through the bag as defined on pages 61 and 62.

Follow these easy steps:

1. Using the desired pipe size and approximate flow rate, determine the basic pressure drop from the appropriate graph.
2. Multiply the pressure drop obtained in step 1 by the viscosity correction factor found in the accompanying table. This is the adjusted (clean) pressure drop for all baskets without filter bags.

Note: Filter bags are specified separately. See page 120-130.



	Viscosity, cps								
	1 (H ₂ O)	50	100	200	400	600	800	1000	2000
All unlined baskets	.65	.85	1.00	1.10	1.20	1.40	1.50	1.60	1.80
40-mesh lined	.73	.95	1.20	1.40	1.50	1.80	1.90	2.00	2.30
60-mesh lined	.77	1.00	1.30	1.60	1.70	2.10	2.20	2.30	2.80
80-mesh lined	.93	1.20	1.50	1.90	2.10	2.40	2.60	2.80	3.50
100-mesh lined	1.00	1.30	1.60	2.20	2.40	2.70	3.00	3.30	4.40
200-mesh lined	1.30	1.70	2.10	3.00	3.40	3.80	4.40	5.00	6.80

Selecting A Size

These descriptions and flow charts can aid in size selection. Capacities given are for each of the two vessels in any duplex system.

Model 4—For flow rates to 50 gpm*

- Pipe sizes 1, 2, or 3 inch, flanged
- Basket depth: 12 inches (nominal)

Basket Data

Depth (nominal, inches)	Diameter (inches)	Surface Area	Volume (cu. in.)
12	3.9	1.0	130

Model 6—For flow rates to 100 gpm*

- Delivers 3.4 square feet of basket or bag surface without need for ASME code construction.
- Can be fitted to hold cartridge filter elements
- Pipe sizes 1, 2, 3, or 4 inches (flanged).
- Two basket depths: 18, or 30 inches (nominal)

Basket Data

Depth (nominal, inches)	Diameter (inches)	Surface Area	Volume (cu. in.)
18	5	2.0	350
30	5	3.4	630

Model 8—For flow rates to 220 gpm*

- Can be fitted to hold cartridge filter elements
- Pipe sizes 2, 3, or 4 inch, flanged.
- Two basket depths: 15 or 30 inches (nominal)

Basket Data

Depth (nominal, inches)	Diameter (inches)	Surface Area	Volume (cu. in.)
15	6.7	2.3	500
30	6.7	4.4	1000

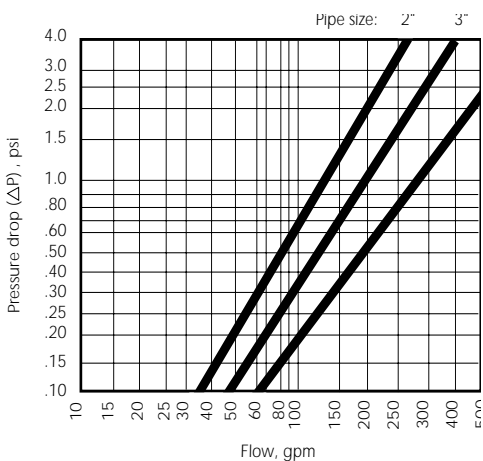
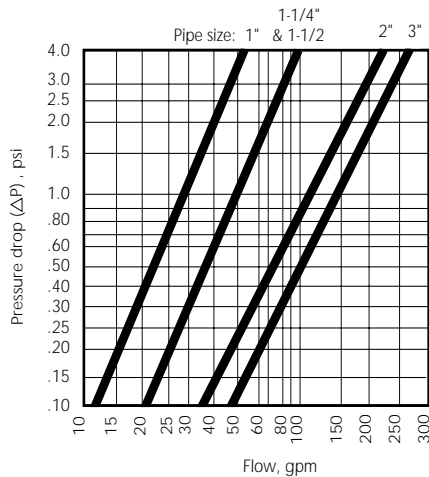
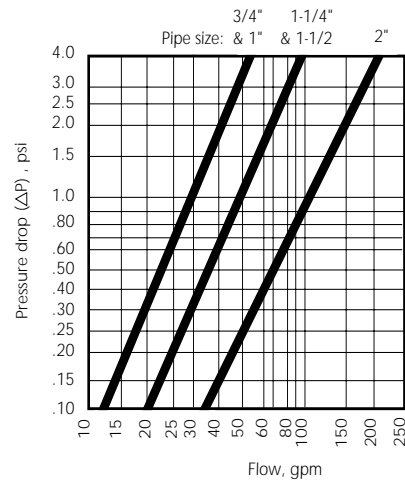

*Based on housing only. Fluid viscosity, filter cartridge used, and expected dirt loading should be considered when sizing a filter.

Single-Basket Models (IN)

Model	Flange Size	A For basket depths				B	B1 (Model 82 only)	C	D	F	G	H	I	J (Model 82 only)
		12	15	18	30									
4	1	18				29.5		9	15	14	19	22.25	7.0	
	2	18				29.5		9	15	14	19	22.25	7.0	
	3	22.125				31.75		11	17	14	19	24.25	7.0	
6	1			25.75	37.75	34.75		9	15	18	20.5	24.25	10.0	
	2			25.75	37.75	34.75		9	15	18	20.5	24.25	10.0	
	3			27.75	39.625	37		11	17	18	20.5	26.25	10.0	
	4			27.625	39.625	41.5		13	18	18	20.5	31	10.0	
8	1		23.75		38.75	44.75	45.75	9	15	22	21.3	32.25	11.6	28.6
	2		23.75		38.75	44.75	45.75	9	15	22	21.3	32.25	11.6	28.6
	3		25.625		40.625	47	48	11	17	22	21.3	34.5	11.6	30.6
	4		25.625		40.625	49.5	50.5	13	18	22	21.3	37	11.6	30.6

The inlets and outlets on all duplex systems come standard in a horizontal configuration (facing opposite directions). The option of arranging the inlet and outlet is available in three positions, 90° apart. The system is designed with flanged tees, allowing the orientation to be changed in the field.

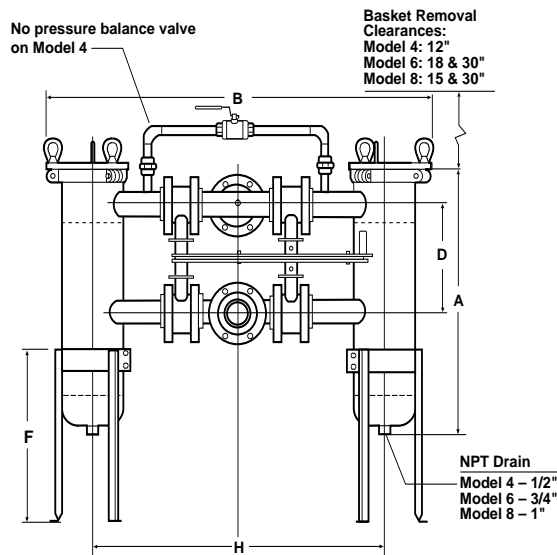
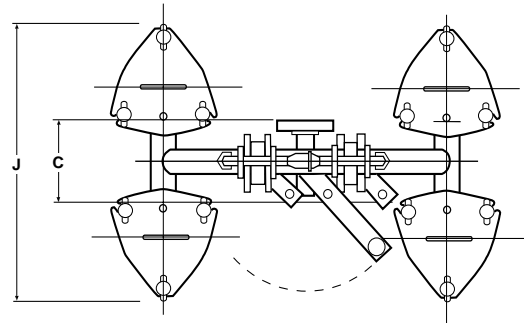
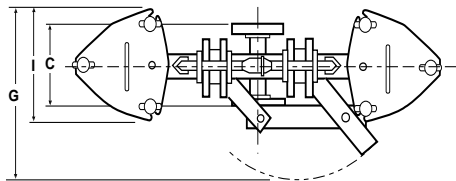

Duplex Models 4, 6, and 8

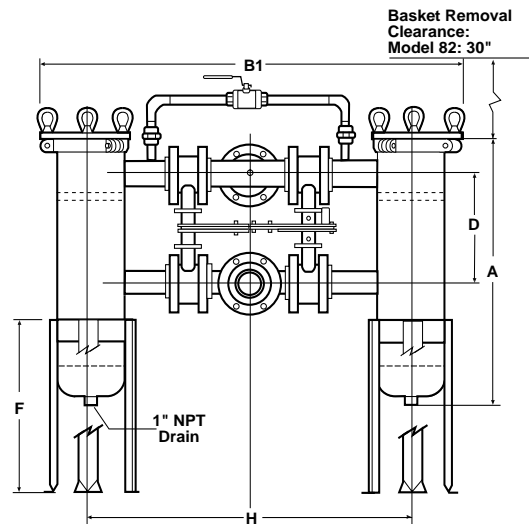

Duplex Model 82

R Duplex Bag Filters With Automatic Sequencing

Continuous, uninterrupted filtering of large flows of liquid is provided by these automatic duplex filters

When the filter bags on one side get to the point of requiring change-out, the incoming flow is automatically diverted to the clean filter bags on the other side. Maintenance personnel are alerted to the need to change the dirty filters so that the system will be ready for the next cycle.

Typical step-by-step operation

1. As the filter bags in vessel A become so loaded with particulate that the differential pressure increases to a selected level, a switch actuates an air-operated valve in the loop pipe. This diverts a small flow of fluid to fill vessel B. After enough time to equalize the pressure in the two vessels, the four main valves are actuated by an air cylinder.
2. The duplex valve system shifts four valves at once, closing the inlet and outlet on vessel A and opening the two on vessel B.

An indicator light (and remote signal, if desired) shows that vessel B is now being utilized. Another light shows that the shift from one vessel to the other has occurred, and that filter bags need to be replaced. An electrical interlock prevents another shift cycle until the dirty filter bags have been replaced and the operator has pushed a reset button.

3. With the interlock released, the system is ready to cycle whenever the pressure differential again indicates the necessity.

Availability

The automatic duplex valve system can be ordered on any Rosedale filter vessel. The standard multi-bag filter models are shown in the table.

The main inlet and outlet connections can be positioned to accommodate any flow direction within reason.

Systems are shipped assembled, ready for use, often on dollies or skids to assist putting them in place.

Rosedale Model No.*	Number of bags	Nominal flow rate, gpm
16	2	400
18	3	600
22	4	800
24	6	1200
30	8	1600
36	12	2000
42	17	3500
48	23	4500

* Model number also indicates vessel diameter in inches.



**Models 16 through 48 -
For flow rates to 4600 gpm**

- Contain from 2 to 23 baskets
- Pipe sizes 2 through 12 inches, flanged
- Two basket depths: 15 or 30 inches (nominal) both 6.7 inches in diameter

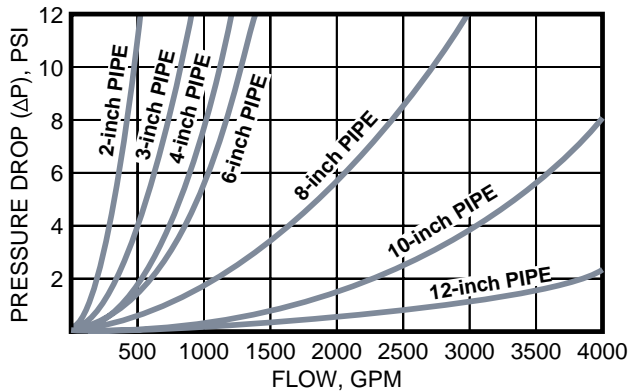

Multi-Basket Models (IN)

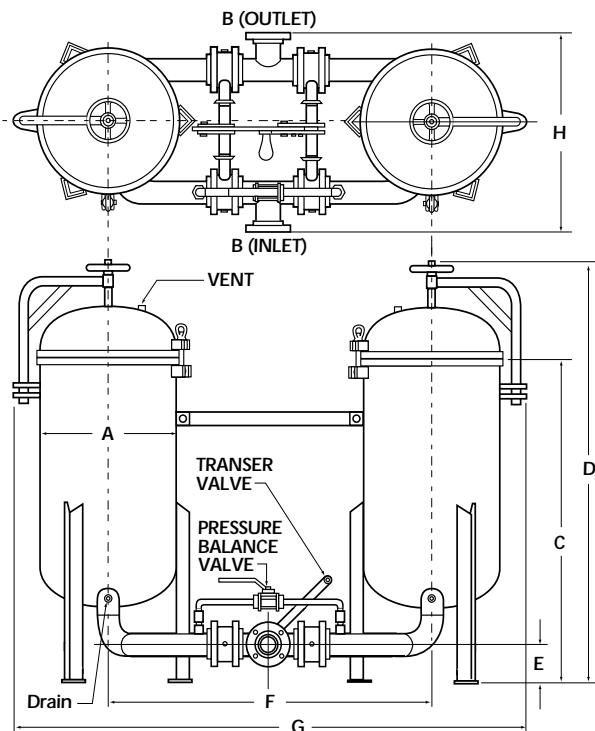

The inlets and outlets on all duplex systems come standard in a horizontal configuration (facing opposite directions). The option of arranging the inlet and outlet is available in three positions, 90° apart. The system is designed with flanged tees, allowing the orientation to be changed in the field.

Model Number	Number of Baskets	Basket Depth (nom.)	Surface Area (sq. ft.)	Flow Rate* (gpm)
16	2	30	8.8	400
18	3	30	13.2	600
22	4	30	17.6	800
24	6	30	26.4	1200
30	8	30	35.2	1600
36	12	30	52.8	2400
42	17	30	74.8	3400
48	23	30	101.2	4600

*Based on housing only. Fluid viscosity, filter cartridge used, and expected dirt loading should be considered when sizing a filter.

Model (Dia.)	Inlet/Outlet	C	D	E	F	G	H
16	2	40.1	57.1	4.5	40.3	65.3	25.3
	3	42.5	59.5	5.3	42.5	67.5	30.3
	4	44.9	61.9	6.0	45.0	70.0	35.0
18	2	40.5	58.0	4.5	42.3	69.3	26.4
	3	42.9	60.4	5.3	44.5	71.5	31.4
	4	45.3	62.8	6.0	47.0	74.0	36.3
22	2	41.4	60.0	4.5	46.3	77.3	24.9
	3	43.9	62.4	5.3	48.5	79.5	28.4
	4	46.2	64.7	6.0	51.0	82.0	31.8
	6	50.4	69.0	7.0	54.3	85.3	37.8
24	2	41.7	60.7	4.5	50.3	83.3	24.1
	3	44.1	63.1	5.3	52.5	85.5	28.8
	4	46.5	65.5	6.0	55.0	88.0	34.1
	6	50.7	69.7	7.0	58.3	91.3	40.1
30	2	42.8	63.3	4.5	56.3	95.3	28.4
	3	45.2	65.7	5.3	58.5	97.5	30.4
	4	47.6	68.1	6.0	61.0	100.0	32.4
	6	51.9	72.4	7.0	64.3	103.3	44.4
	8	56.4	76.8	8.3	67.0	106.0	49.4
36	3	46.4	68.4	5.3	64.5	109.5	34.1
	4	48.8	70.8	6.0	67.0	112.0	36.1
	6	53.1	75.1	7.0	70.3	115.3	39.1
	8	57.6	79.6	8.3	73.0	118.0	41.1
	10	62.1	84.1	9.5	77.0	122.0	60.1
42	4	50.0	73.5	6.0	73.0	124.0	40.1
	6	54.3	77.8	7.0	76.3	127.3	43.1
	8	58.8	82.3	8.3	79.0	130.0	45.1
	10	63.3	86.8	9.5	83.0	134.0	49.1
	12	68.0	91.5	11.0	86.0	137.0	69.1
48	4	51.0	76.0	6.0	79.0	136.0	44.5
	6	55.4	80.4	7.0	82.3	139.3	47.5
	8	60.0	85.0	8.3	85.0	142.0	49.5
	10	64.4	89.4	9.5	89.0	146.0	53.5
	12	69.2	94.2	11.0	92.0	149.0	55.5

How To Order

Build an ordering code as shown in the example.

Housing		Options		OPTIONAL INNER BASKET	AUTOMATIC DUPLEX CONTROL OPTIONS
Example:	D16	-30-	4F-1-150-C-B-S-M-200-DPG-D-C-	2M-50-	EP
MODEL Duplex Style = D Automatic Duplex = AD					
MODEL NO. 4 = 4 6 = 6 8 = 8 16 = 16 18 = 18 22 = 22 24 = 24 30 = 30 36 = 36 42 = 42 48 = 48 82 = 82					
BASKET DEPTH 12-in. = 12 15-in. = 15 18-in. = 18 30-in. = 30					
CONNECTION SIZES, FLANGED¹ 1-in. (Models 4 thru 48) = 1F 2-in. (Models 4 thru 48) = 2F 3-in. (Models 4 thru 48) = 3F 4-in. (Models 6 thru 48) = 4F 6-in. (Models 22 thru 48) = 6F 8-in. (Models 30 thru 48) = 8F 10-in. (Models 36 and 48) = 10F 12-in. (Models 42 and 48) = 12F					
OUTLET STYLE Standard = 1					
PRESSURE RATINGS² 150psi (flanged) = 150					
CONSTRUCTION MATERIAL Carbon steel = C 304 stainless steel = S 316 stainless steel = S316					
COVER SEAL Buna N = B Ethylene Propylene = E Viton® = V Teflon® Encapsulated Viton® = TEV Teflon® (solid white) = TSW					
BASKET SEAL No Seal (never on Model 4, 6, or multi-bag filters) = N Seal wanted (always on Model 8 bag filters) = S					
				OPTIONAL INNER BASKET, MEDIA SIZE. No symbol if type 2B basket was selected Perforation diameters (for type 2P baskets) 1/4, 3/16, 9/64, 3/32, 1/16 Mesh sizes (for type 2M and 2BM baskets) 20, 30, 40, 50, 60, 70, 80, 100, 150, 200	AUTOMATIC DUPLEX CONTROL OPTIONS EP = Electric controller/Pneumatic actuators EE = Electric controller/Electric actuators PP = Pneumatic controller/Pneumatic actuators JB = Junction Box
				OPTIONAL INNER BASKET TYPE 2PB = Filter bag basket, 9/64 perforations ³ 2P = Strainer basket, perforated metal 2BM = Filter bag basket, perforated, mesh lined ³ 2M = Strainer basket, perforated, mesh lined	
				ASME CODE STAMP C = Code Stamp	
				DISPLACER D = Displacer	
				DIFFERENTIAL PRESSURE GAUGE DPG = Gauge System DPS = Switch	
				BASKET, MEDIA SIZE No symbol if type B basket was selected Perforation diameters (for type P baskets) 1/4, 3/16, 9/64, 3/32, 1/16 Mesh sizes (for type M and BM baskets) 20, 30, 40, 50, 60, 70, 80, 100, 150, 200	
				BASKET TYPE PB = Filter bag basket, 9/64 perforations ³ P = Strainer basket, perforated metal BM = Filter bag basket, perforated, mesh lined ³ M = Strainer basket, heavy wire mesh ³	

1. Flanges provided with the housing match the pressure rating of the vessel. Housings rated 150 psi have 150 class flanges. ANSI B16.5 Pressure-Temperature rating tables determine flange class for ASME housings.
2. Higher pressure ratings available. Consult factory.
3. Filter bags are ordered separately. See pages 120-130.