

Model 6 Basket Strainer and Bag Filters

Strainers or Bag Filters:
Your Choice!

Model 6 strainer/filter housings are made in 3 sizes and 3 pressure ratings, and can serve as basket strainers (for particle retention down to 74 micron size) or as bag filters (for particle retention down to 1 micron size). In all cases, covers are easily removed without special tools, and the basket or bag is easily cleaned or replaced.

Features

- Low pressure drops
- Permanently piped housings
- Covers are O-ring sealed
- Carbon steel, or stainless steel (304 or 316) construction for housings
- All housings are electropolished to resist adhesion of dirt and scale
- Easy to clean!
- Adjustable-height legs, standard
- O-ring seals: Buna N, EPR, Viton®, Teflon®
- ASME code stamp available
- Three pressure ratings: 150, 210 or 300 psi
- Duplex units are available
- Can provide 3.4 square feet of basket or bag surface area without need for ASME code construction
- Three basket depths: 12, 18, or 30 inches (nominal)
- Special alloys

Options

- Sanitary construction
- Different outlet connections
- Higher pressure ratings
- Extra-length legs
- Heat jacketing
- Liquid displacers for easier servicing



Covers are secured by three eyenut assemblies. One of them acts as a hinge, when the cover is opened.



Choosing a Basket Strainer or Bag Filter

Choose between straining (removing particles down to 74 micron size) or filtering a fluid (removing particles down to 1 micron). This will direct you to the correct basket when ordering.

Operation

Unfiltered liquid enters the housing above the bag or basket and passes down through them. Solids are contained inside the bag or basket, where they are easily and completely removed when the unit is serviced.

Fluid bypass around the basket is prevented because the outside diameter of the bag filter seals against the housing inside diameter.

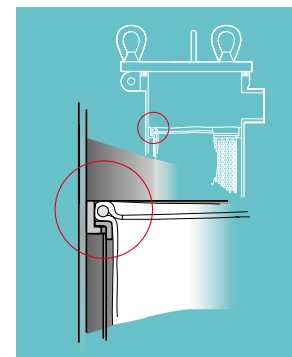

A single cover gasket is used to seal the opening, and covers can be installed and removed without tools.

Pressure Drop Data

Basket strainers and bag filters are usually selected so that the pressure drop does not exceed 2 psi, when they are clean. Higher pressure drops may be tolerated, when contaminant loading is low. Bag change should occur at 15psid.

The pressure drop data is accurate for all housings with strainer or bag filter baskets. When bag filters are added, total pressure drop becomes the sum of the pressure drop as determined by the steps below, plus the pressure drop through the bag as defined in Rosedale Filter Bag section.

Follow these easy steps:

1. Using the desired pipe size and approximate flow rate, determine the basic pressure drop from the appropriate graph.
2. Multiply the pressure drop obtained in step 1 by the viscosity correction factor found in the accompanying table. This is the adjusted (clean) pressure drop for all baskets, without bag filters.
3. Add the pressure drop for the bag filter.

Note: Filter bags are specified separately. See page 120-130.

	Viscosity, cps								
	1 (H ₂ O)	50	100	200	400	600	800	1000	2000
All unlined baskets	.65	.85	1.00	1.10	1.20	1.40	1.50	1.60	1.80
40-mesh lined	.73	.95	1.20	1.40	1.50	1.80	1.90	2.00	2.30
60-mesh lined	.77	1.00	1.30	1.60	1.70	2.10	2.20	2.30	2.80
80-mesh lined	.93	1.20	1.50	1.90	2.10	2.40	2.60	2.80	3.50
100-mesh lined	1.00	1.30	1.60	2.20	2.40	2.70	3.00	3.30	4.40
200-mesh lined	1.30	1.70	2.10	3.00	3.40	3.80	4.40	5.00	6.80

Basket Data

Depth Nominal (inches)	Diameter (inches)	Surface Area (sq. ft.)	Volume (cu. in.)	Bag Size No.
12	5	1.3	235	7
18	5	2.0	350	8
30	5	3.4	630	9

Model 6-For flow rates to 100 gpm*

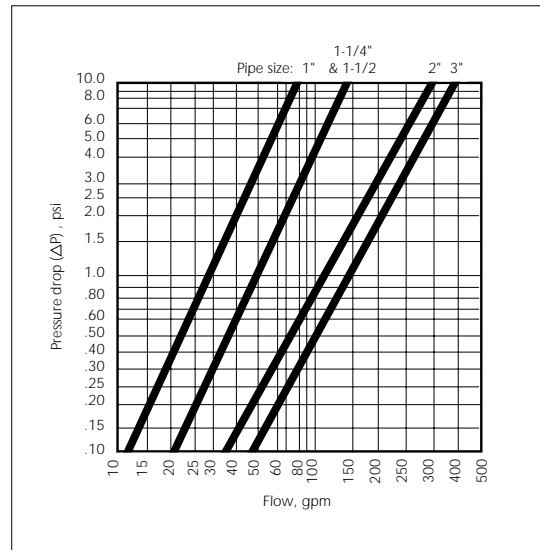

*Based on housing only. Fluid viscosity, bag filter used, and expected dirt loading should be considered when sizing a filter.



Eyeout covers with bag filter and basket or basket strainer.

Dimensions (IN)

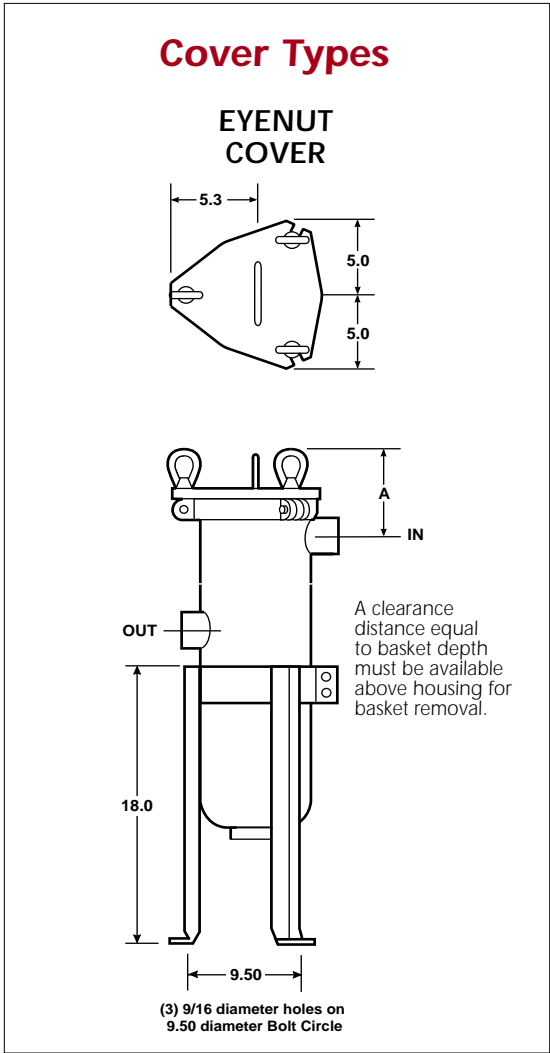

Outlet Styles

Flanged
(150 lb. ANSI)

Threaded
(NPT)

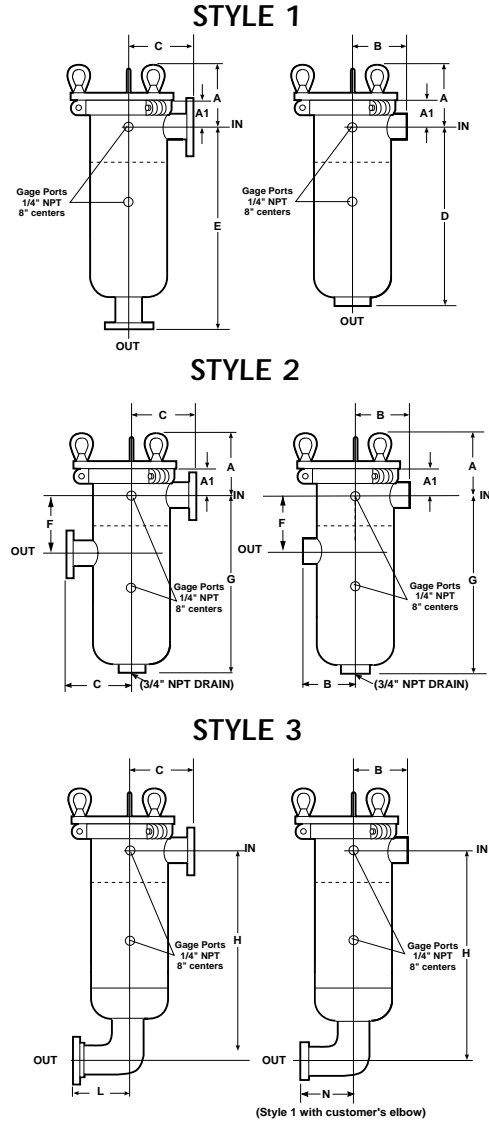

Dimensions (IN)

Model	Pipe Size	A	A1	B	C	D	E	F	G	H	L	N
6-12	1	6.3	2.5	4.3	6.0	17.6	19.0	4.3	17.4	18.1	5.0	2.5
	1-1/4	6.3	2.5	4.3	6.0	17.6	19.0	4.7	17.4	18.4	5.0	2.9
	1-1/2	6.3	2.5	4.3	6.0	17.6	19.0	4.7	17.4	18.8	5.0	3.3
	2	7.1	3.4	4.3	6.0	16.6	19.0	6.6	16.5	18.6	5.0	4.0
	3	7.1	3.4	4.3	6.0	17.0	19.0	6.6	16.5	19.9	7.3	6.1
6-18	1	6.3	2.5	4.3	6.0	22.8	24.3	4.3	22.7	23.3	5.0	2.5
	1-1/4	6.3	2.5	4.3	6.0	22.8	24.3	4.7	22.7	23.7	5.0	2.9
	1-1/2	6.3	2.5	4.3	6.0	22.8	24.3	4.7	22.7	24.0	5.0	3.3
	2	7.1	3.4	4.3	6.0	21.8	24.3	6.6	21.8	23.8	5.0	4.0
	3	7.1	3.4	4.3	6.0	22.3	24.3	6.6	21.8	25.3	7.3	6.1
6-30	1	6.3	2.5	4.3	6.0	32.8	34.3	4.3	32.7	33.3	5.0	2.5
	1-1/4	6.3	2.5	4.3	6.0	32.8	34.3	4.7	32.7	33.7	5.0	2.9
	1-1/2	6.3	2.5	4.3	6.0	32.8	34.3	4.7	32.7	34.0	5.0	3.3
	2	7.1	3.4	4.3	6.0	31.8	34.3	6.6	31.8	33.8	5.0	4.0
	3	7.1	3.4	4.3	6.0	32.3	34.3	6.6	31.8	35.3	7.3	6.1



How To Order

Build an ordering code as shown in the example

Example: 6 - 30 - 3P - 1 - 300 - C - B - S - M 200 - D - C

<p>MODEL NO. 6 = 6</p> <p>HOUSING SIZE 12 inch = 12 18 inch = 18 30 inch = 30</p> <p>PIPE SIZE, NPT and FLANGED¹ 3/4-in. female NPT = 3/4P 1-in. female NPT = 1P 1-1/4-in. female NPT = 1-1/4P 1-1/2-in. female NPT = 1-1/2P 2-in. female NPT = 2P 3-in. female NPT = 3P 3/4-in. 150 class ANSI flange = 3/4F 1-in. 150 class ANSI flange = 1F 1-1/4-in. 150 class ANSI flange = 1-1/4F 1-1/2-in. 150 class ANSI flange = 1-1/2F 2-in. 150 class ANSI flange = 2F 3-in. 150 class ANSI flange = 3F</p> <p>OUTLET STYLE Bottom = 1 Side = 2 Bottom elbow = 3</p> <p>PRESSURE RATING² 150 psi (flanged or NPT) = 150 210 psi (flanged or NPT) = 210 300 psi (flanged or NPT) = 300</p> <p>HOUSING MATERIAL Carbon steel = C 304 stainless steel = S 316 stainless steel = S316</p>	<p>ASME CODE STAMP C = Code</p> <p>DISPLACER D = Displacer</p> <p>BASKET, MEDIA SIZE No symbol if type B basket was selected Perforation diameters (for type P baskets) 1/4, 3/16, 9/64, 3/32, 1/16 Mesh sizes (for type M and BM baskets) 20, 30, 40, 50, 60, 70, 80, 100, 150, 200</p> <p>BASKET TYPE PB = Filter bag basket, 9/64 perforations³ P = Strainer basket, perforated metal BM = Filter bag basket, perforated, mesh lined³ M = Strainer basket, perforated, mesh lined HWM = Filter bag basket, heavy wire mesh³</p> <p>BASKET SEAL N = No seal (never on Models 4 & 6 bag-type baskets) S = Seal required (always on Model 8 bag-type baskets)</p> <p>COVER SEAL B = Buna N E = Ethylene Propylene V = Viton® Fluoroelastomer TEV = Teflon® Encapsulated Viton® TSW = Teflon® (solid white)</p>
---	--

1. Flanges provided with the housing match the pressure rating of the vessel. Housings rated 150 psi have 150 class flanges. Housings rated 300 psi have 300 class flanges. ANSI B16.5 Pressure-Temperature rating tables determine flange class for ASME code housings. Consult factory.
2. Higher pressure ratings available. Consult factory.
3. Filter bags are specified separately. See page 120-130.
4. 150 psi unit has 150 class flanges. 300 psi unit has 300 class flanges. 210 psi unit available only in NPT.