

Model 8 Basket Strainer and Bag Filters

Strainers or bag filters:
Your choice!

Model 8 strainer/filter housings are made in 2 sizes and 2 pressure ratings, and can serve as basket strainers (for particle retention down to 74 micron size) or as bag filters (for particle retention down to 1 micron size). In all cases, covers are easily removed, without tools, and the basket or bag is easily cleaned or replaced.

Features

- Low pressure drops
- Permanently piped housings
- Covers are O-ring sealed
- Carbon steel, or stainless steel (304 or 316) construction for housings
- All housings are electropolished to resist adhesion of dirt and scale
- Easy to clean!
- Adjustable-height legs, standard
- Large-area, heavy-duty baskets
- O-ring seals: Buna N, EPR, Viton®, Teflon®
- ASME code stamp available
- Two pressure ratings: 150 and 300
- Duplex units are available
- Pipe sizes 3/4 thru 6-inch, NPT or flanged
- Two basket depths: 15 or 30 inches (nominal)

Options

- Sanitary construction
- Different outlet connections
- Higher pressure ratings
- Extra-length legs
- Heat jacketing
- Adapters for holding filter cartridges.
- Liquid displacers for easier servicing
- Can be fitted with an adapter to hold cartridge filter elements



Covers are secured by three eyenut assemblies. One of them acts as a hinge, when the cover is opened.



Dual Stage Straining/Filter

All Rosedale Model 8 housings can be supplied with a second, inner basket, which is supported on the top flange of the regular basket. Both baskets can be strainers (with or without wire mesh linings) or both can be baskets for filter bags. They can also be mixed: one a strainer basket, the other a filter bag basket. Dual-stage action will increase strainer or filter life and reduce servicing needs.

Choosing A Basket Strainer Or Bag Filter

Choose between straining (removing particles down to 74 micron size) or filtering a fluid (removing particles down to 1 micron). This will direct you in selecting the correct basket when ordering.

Operation

Unfiltered liquid enters the housing above the bag or basket and passes down through them. Solids are contained inside the bag or basket, where they are easily removed when the unit is serviced.

A basket bail is pushed down by the closed cover to hold the basket against a positive stop in the housing. A radial seal prevents bypass of unfiltered liquid.

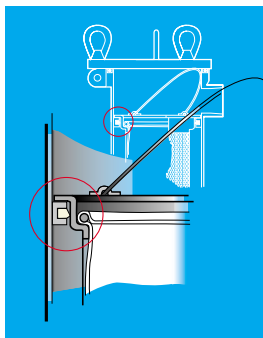

	Viscosity, cps								
	1 (H ₂ O)	50	100	200	400	600	800	1000	2000
All unlined baskets	.65	.85	1.00	1.10	1.20	1.40	1.50	1.60	1.80
40-mesh lined	.73	.95	1.20	1.40	1.50	1.80	1.90	2.00	2.30
60-mesh lined	.77	1.00	1.30	1.60	1.70	2.10	2.20	2.30	2.80
80-mesh lined	.93	1.20	1.50	1.90	2.10	2.40	2.60	2.80	3.50
100-mesh lined	1.00	1.30	1.60	2.20	2.40	2.70	3.00	3.30	4.40
200-mesh lined	1.30	1.70	2.10	3.00	3.40	3.80	4.40	5.00	6.80

Model 8-For flow rates to 220 gpm*

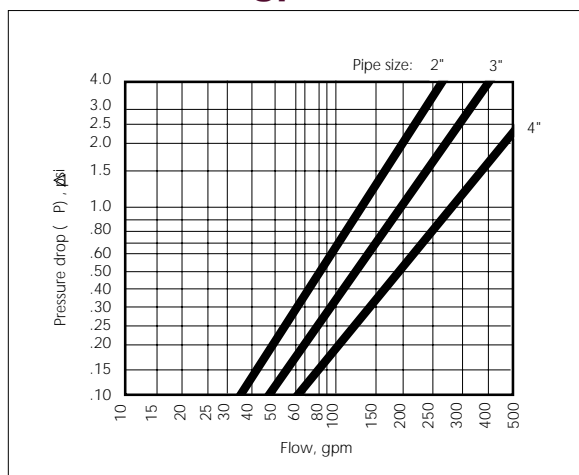

*Based on housing only. Fluid viscosity, filter bag used, and expected dirt loading should be considered when sizing a filter.

Pressure Drop Data

Basket strainers and bag filters are usually selected so that the pressure drop does not exceed 2 psi, when they are clean. Higher pressure drops may be tolerated, when contaminant loading is low. Bag change occurs at 15psid.

The pressure drop data is accurate for all housings with strainer or filter bag baskets. When filter bags are added, total pressure drop becomes the sum of the pressure drop as determined by the steps below.

Follow these easy steps:

1. Using the desired pipe size and approximate flow rate, determine the basic pressure drop from the appropriate graph.
2. Multiply the pressure drop obtained in step 1 by the viscosity correction factor found in the accompanying table. This is the adjusted (clean) pressure drop for all baskets without filter bags.
3. Add the pressure drop for the bag.

Note: Filter bags are specified separately. See page 120-130.

Basket Data

Depth Nominal (inches)	Diameter (inches)	Surface Area (sq. ft.)	Volume (cu. in.)	Bag Size No.
15	6.7	2.3	500	1
30	6.7	4.4	1000	2



Eyenut covers with filter bag and basket.

Dimensions (IN)

Outlet Styles

Flanged
(150 lb. ANSI)

Threaded
(NPT)

STYLE 1

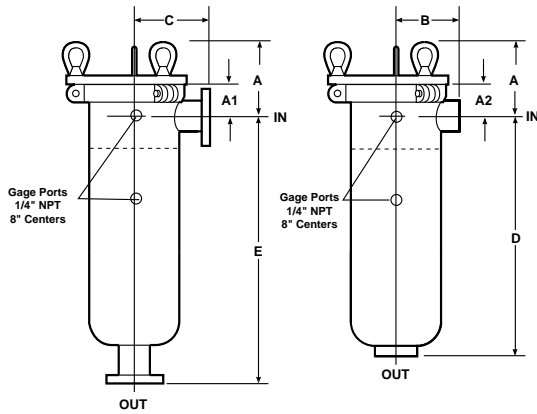

Outlet Styles

Flanged
(300 lb. ANSI)

Threaded
(NPT)

STYLE 1

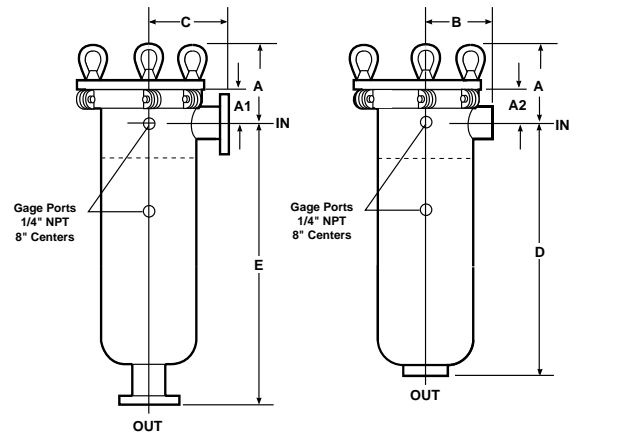

STYLE 2

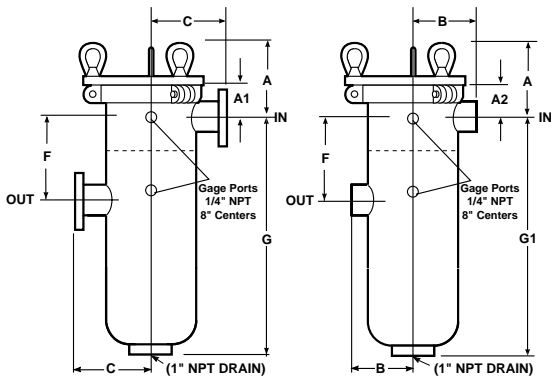

STYLE 2

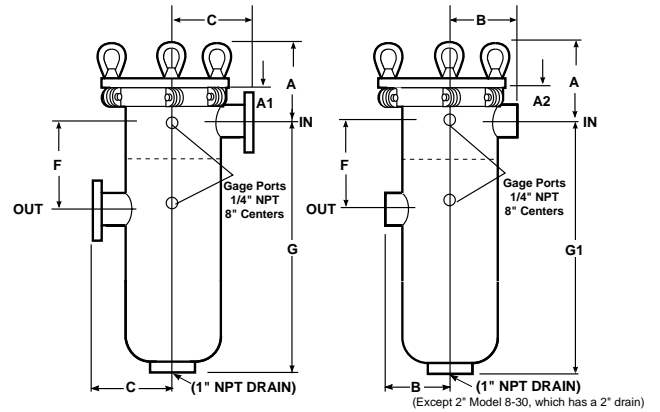

STYLE 3

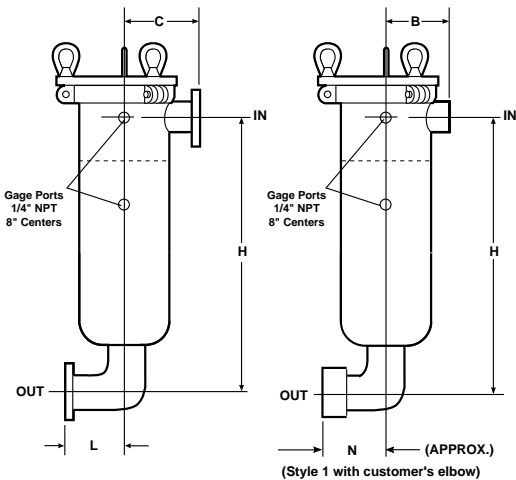

STYLE 3

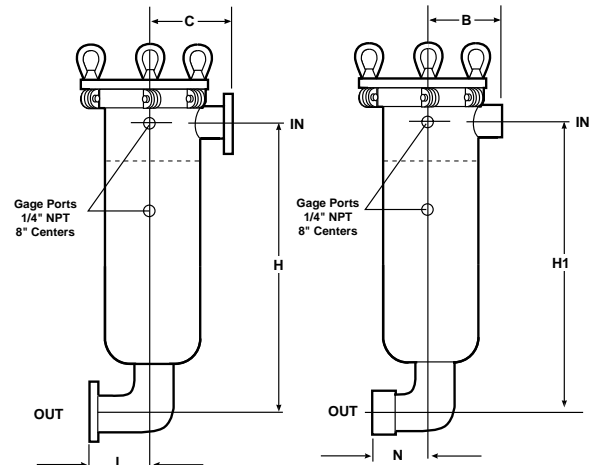

(Style 1 with customer's elbow)

Cover Types

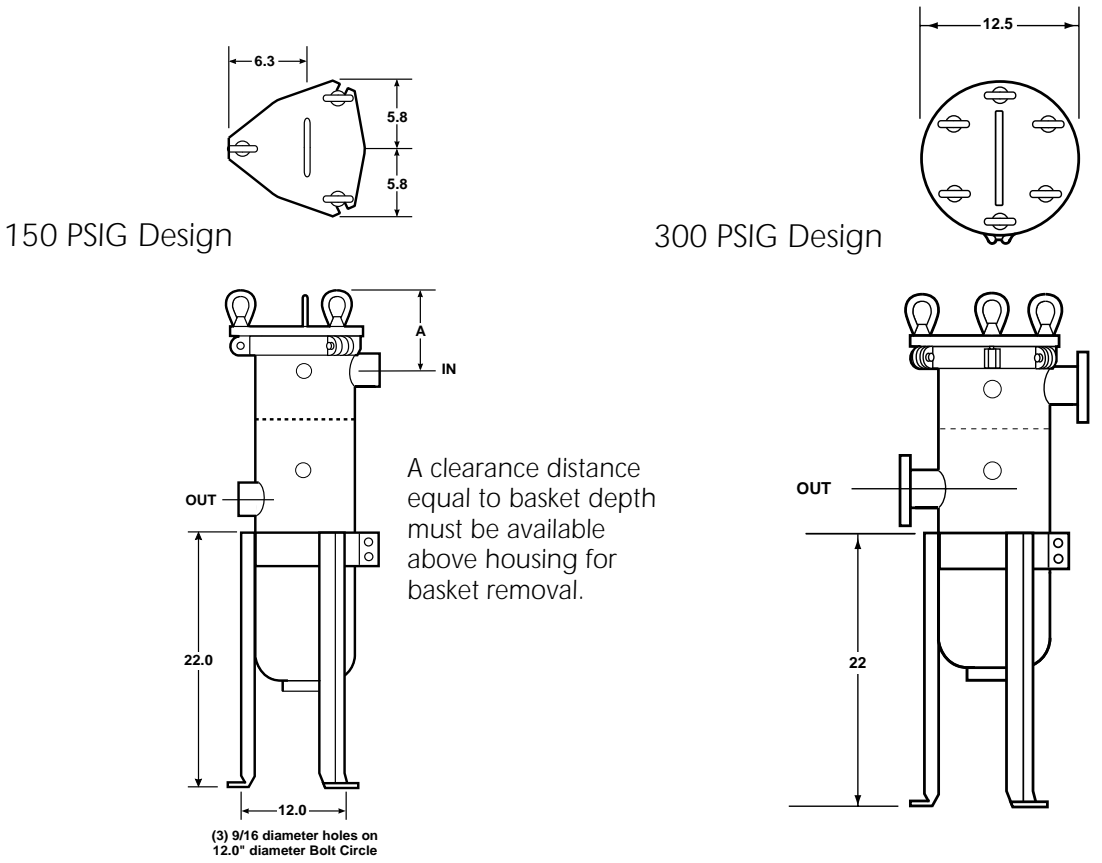

Dimensions (IN) 150 PSIG Design

Model	Pipe Size	A	A1	A2	B	C	D	E	F	G	G1	H	H1	L	N
8-15	2	6.6	2.9	2.9	5.9	7.5	21.2	23.5	4.9	21.0	21.0	23.2	23.2	5.0	4.06
	3	7.5	3.7	3.7	6.8	7.5	22.5	24.6	6.6	21.9	21.9	25.4	25.4	7.25	6.12
	4	7.5	3.7	5.0	6.8	8.6	22.5	25.1	8.4	21.9	20.6	26.8	25.6	9.0	7.75
	6	9.0	5.2	5.9	7.1	8.6	23.6	26.0	9.0	23.4	22.8	30.9	30.3	12.5	11.0
8-30	2	6.6	2.8	2.9	5.9	7.5	36.2	38.5	4.9	36.0	36.0	38.2	38.2	5.0	4.06
	3	7.5	3.7	3.7	6.7	7.5	37.5	39.6	6.6	36.9	36.9	40.4	40.4	7.25	6.12
	4	7.5	3.7	5.0	6.7	8.6	37.5	40.1	8.4	36.9	35.6	41.8	40.6	9.0	7.75
	6	9.0	5.2	5.9	7.1	8.6	38.6	41.0	9.0	38.4	37.8	45.9	45.3	12.5	11.0

Dimensions (IN) 300 PSIG Design

Model	Pipe Size	A	A1/A2	B	C	D	E	F	G/G1	H/H1	L	N
8-15	2	7.6	3.8	5.9	7.5	21.2	23.5	4.9	21.0	23.2	5.0	4.06
	3	8.9	5.0	6.8	8.6	22.5	24.6	6.6	21.9	25.4	7.25	6.12
	4	8.9	5.0	6.8	9.6	22.5	25.1	8.4	21.9	26.8	9.0	7.75
	6	10.1	6.2	6.3	10.0	23.6	26.0	9.0	23.4	30.9	12.5	11.0
8-30	2	7.6	3.8	5.9	7.5	36.0	38.5	4.9	36.0	38.2	5.0	4.06
	3	8.9	5.0	6.8	7.5	36.7	39.6	6.6	36.9	40.4	7.25	6.12
	4	8.9	5.0	6.8	8.6	36.5	40.1	8.4	36.9	41.8	9.0	7.75
	6	10.1	6.2	7.1	8.6	38.6	41.0	9.0	38.4	45.9	12.5	11.0

R How To Order

Build an ordering code as shown in the example

Example: **8-15-3P-1-150-C-B-S-M-200-D-C - 2M 50**

MODEL NO.
8 = 8

HOUSING SIZE
15 inch = 15
30 inch = 30

PIPE SIZE, NPT and FLANGED¹
3/4-in. female NPT = 3/4P
1-in. female NPT = 1P
1-1/4-in. female NPT = 1-1/4P
1-1/2-in. female NPT = 1-1/2P
2-in. female NPT = 2P
3-in. female NPT = 3P
3/4-in. 150 class ANSI flange = 3/4F
1-in. 150 class ANSI flange = 1F
1-1/4-in. 150 class ANSI flange = 1-1/4F
1-1/2-in. 150 class ANSI flange = 1-1/2F
2-in. 150 class ANSI flange = 2F
3-in. 150 class ANSI flange = 3F
4-in. 150 class ANSI flange = 4F
6-in. 150 class ANSI flange = 6F

OUTLET STYLE
Bottom = 1
Side = 2
Bottom elbow = 3

PRESSURE RATING²
150 psi (NPT or flanged) = 150
300 psi (NPT or flanged) = 300

HOUSING MATERIAL
Carbon steel = C
304 stainless steel = S
316 stainless steel = S316

COVER SEAL
Buna N = B
Ethylene Propylene = E
Viton® Fluoroelastomer = V
Teflon® Encapsulated Viton® (6 Bolt Cover) = TEV
Teflon® (solid white) = TSW

BASKET SEAL
Seal required = S

NOTE:

- Flanges provided with the housing match the pressure rating of the vessel. Housings rated 150 psi have 150 class flanges. Housings rated 300 psi have 300 class flanges. ANSI B16.5 Pressure-Temperature rating tables determine flange class for ASME code housings. Consult factory.
- Higher pressure ratings available. Consult factory.
- Filter bags are specified separately. See page 120-130.
- 150 psi unit has 150 class flanges. 300 psi unit has 300 class flanges.

OPTIONAL INNER BASKET

FOR MODEL 8 ONLY
OPTIONAL INNER BASKET, MEDIA SIZE-No symbol if type 2B basket was selected

Perforation diameters (for type 2P baskets)
1/4, 3/16, 9/64, 3/32, 1/16

Mesh sizes (for type 2M and 2BM baskets) 20, 30, 40, 50, 60, 70, 80, 100, 150, 200

OPTIONAL INNER BASKET TYPE

- 2B** = Filter bag basket, 9/94 perforations³
- 2P** = Strainer basket, perforated metal
- 2BM** = Filter bag basket, perforated, mesh lined³
- 2M** = Strainer basket, perforated, mesh lined

ASME CODE STAMP

C = Code

DISPLACER

D = Displacer

BASKET, MEDIA SIZE-No symbol if type B basket was selected

Perforation diameters (for type P baskets)
1/4, 3/16, 9/64, 3/32, 1/16

Mesh sizes (for type M and BM baskets)
20, 30, 40, 50, 60, 70, 80, 100, 150, 200

BASKET TYPE

- PB** = Filter bag basket, 9/64 perforations³
- P** = Strainer basket, perforated metal
- BM** = Filter bag basket, perforated, mesh lined³
- M** = Strainer basket, perforated, mesh lined
- HWM** = Filter bag basket, heavy wire mesh³