

Model NCO Bag or Cartridge Filter Housings

Low cost filter housings for flow rates to 100 gpm*

NCO high-capacity filters offer an exceptional value in basic filtration applications. Offered in a size 2 and size 12 bag housing, the NCO is also available with our Platinum 700 cartridge series.

NCO housings provide large dirt-holding capacity combined with a rugged design rated to 150 psi. The housings incorporate a newly designed hinged, eyenut cover that is easily removed, reducing time spent on bag or cartridge change-out. The NCO bag housing offers versatility for any piping arrangement, utilizing our unistyle design (side and bottom outlet). Two connection sizes are available for both bag and cartridge filters.

The NCO housings are electropolished creating a smooth, easy-to-clean surface. Customize them with several options including, gauges and switches. A variety of filter bags or cartridges (rated 0.5 μ absolute to 100 μ nominal) can be utilized in this housing. Keep your filtration process cost effective without sacrificing quality.

Features

- Permanently piped housings are opened without special tools
- Carbon or stainless steel housings
- Covers are O-ring sealed
- O-ring seals: Buna N, EPR and Viton®
- 150 psi rated housing
- Heavy-duty basket, over 50% open area
- Uses standard number 1, 2 or 12 size bags and 500 or 700 series cartridges
- Filter selection surface area is:
 - 2.3 square feet (number 1 size bag),
 - 4.4 square feet (number 2 size bag),
 - 5.6 square feet (number 12 size bag)
- 85 square feet (500 series cartridge)
- 125 square feet (700 series cartridge)
- 1-1/2-inch or 2-inch NPT inlet and outlet
- 1/4-inch NPT vent connection
- Adjustable leg assembly

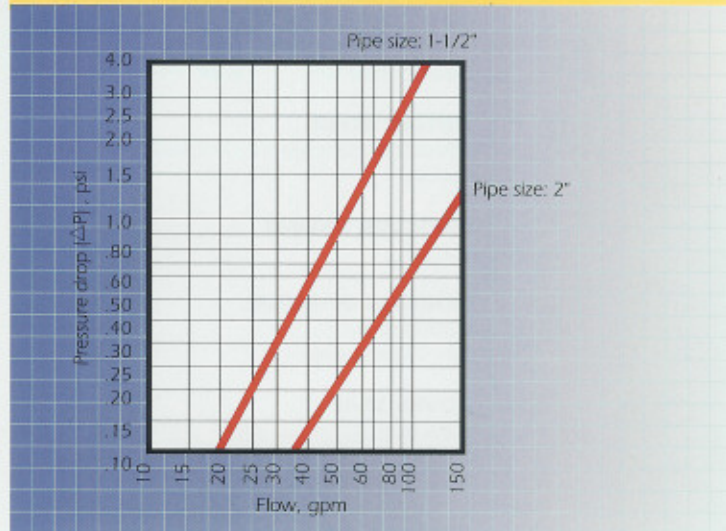

* Based on housing only. Fluid viscosity, filter bag used, and expected dirt loading should be considered when sizing a filter.

How To Order

Build an ordering code as shown in the example.



QUALITY SYSTEM
REGISTERED TO
ISO 9001:1994

	Housing	Options
Example :	NCO8-30 - 2P - * - 150 - C - B - PB	
MODEL		
NCO8 (#1, #2 bag & 500 cartridge)		
NLCO8 (#12 bag)		
NCO8135 (700 cartridge)		
NCO8135 convertible		
BASKET SIZE		
1.5-inch (NCO only)	= 15	
30-inch (NCO or NLCO)	= 30	
NCO8135	= No Symbol	
PIPE SIZE		
1-1/2-inch female NPT	= 1-1/2P	
2-inch female NPT	= 2P	
OUTLET STYLE		
Side/Bottom Unistyle (NCO or NLCO)	= *	
Bottom	= 1	
PRESSURE RATING		
150 psi	= 150	
HOUSING MATERIAL		
Carbon steel	= C	
304 Stainless steel	= S	
COVER SEAL		
Buna N	= B	
Ethylene propylene	= E	
Viton® Fluoroelastomer	= V	
BASKET TYPE		
Filter bag basket (NCO or NLCO)	= PB	
700 Cartridge (NCO8135)	= 700	
Convertible (NCO8135)	= 700PB	

- Filter bags are specified separately. See Rosedale Master Catalog 3rd edition.
- Basket material is compatible with housing.
- Weight (approximately): 70 lbs.

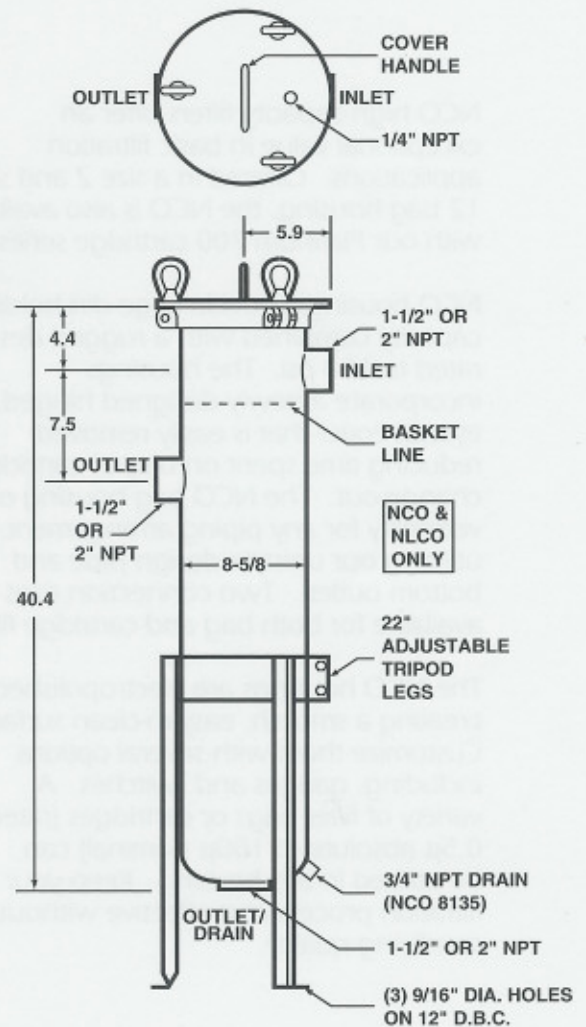

Rosedale Products, Inc.

3730 W. Liberty Rd, Ann Arbor, MI 48103
 Tel: 800-821-5373 or 734-665-8201
 Fax: 734-665-2214
<http://www.rosedaleproducts.com/>
 E-mail: filters@rosedaleproducts.com



Call us today for our complete catalog or visit our web site to see our entire product line.